



Lift Load Mark III



Operators Manual

Revised October 30, 2012

2 Dartmouth Road
Bedford, Nova Scotia
B4A 2K7

www.healthassociation.ns.ca

Contents

- 1 Product Description 4
 - 1.1 Lift Load 5
 - 1.1.1 Frame Assembly 7
 - 1.1.2 Lift Load Weights 9
 - 1.2 Carry Bar – Testing Accessory 10
 - 1.2.1 Carry Bar Assembly 11
 - 1.3 Tub Seat Adapter – Testing Accessory 12
 - 1.3.1 Tub Seat Adapter Assembly 13
- 2 Warnings and Cautions for Use 13

WARRANTY STATEMENT

Quality Machining Services Ltd. warrants the products it offers, to the original purchaser only, to be free from defects in materials and workmanship under normal use and service for a period of one year from date of purchase. Quality Machining Services Ltd. reserves the option to replace any defective part(s) or issue credit at the original sale price only.

There are no representations, warranties or conditions expressed or implied, statutory or otherwise, except those herein contained. Quality Machining Services Ltd. assumes no liability for damages, losses or injuries direct or consequential that may arise from the use or inability to use its products. Any part(s) damaged as a result of misuse, dropping, alteration or any other abuse, will not be given warranty consideration regardless of the original claimed defect.

This warranty does not cover defects or malfunctions which result from causes beyond our control, including, without limitation:

1. Alteration outside of manufacturer’s factory in any way that negatively affects the integrity of the product.
2. Misuse, abuse, accident, neglect or other abnormal use.

Defective part(s) may be returned to Quality Machining Services Ltd. only after authorization has been granted by Quality Machining Services Ltd. Routing for returned part(s) shall be in the most cost effective manner.

WARRANTOR

Quality Machining Services Ltd. 98 Morrison Drive, Windsor NS, B0N 2T0 1-902-798-8605

1 Product Description

Health Association Nova Scotia, in conjunction with Stantec Engineering and Quality Machining, has developed a Lift Load for testing of patient and resident lifts used in Healthcare facilities. The concept behind the Lift Load is to provide a safe and efficient multipurpose test load for the healthcare environment. This is achieved by:

- 1) Permanently/Initially locating the majority of the low cost Pumpkin Weights at each facility, where testing takes place, in order to minimize the requirement for heavy lifting. Thus reducing the risk of injury for users.
- 2) Incorporating features into the cart that eliminates the need to lift heavy weights to load the cart. Only the cart, accessories, and small wafer weights (12.5-lbs.) are routinely transported to a facility. Users should never have to routinely lift any component of the system weighing more than 18 lbs.
- 3) Implementing a low profile design which clears obstacles when lifted.
- 4) Maximizing portability through an easily disassembled cart designed for transport in a small vehicle.
- 5) Ensuring the Lift Load is patient, resident, user, and facility friendly (i.e. rolls easily/quietly without marking floors).
- 6) Providing multiple options for load configurations of the cart and accessories allowing for connection to a very broad variety of lifting technologies.
- 7) Providing a platform that will easily handle 1,250-lbs.

1.1 Lift Load

The Lift Load cart is comprised of 6 parts. The assembled cart is made from nickel-plated aluminum weighing approximately 72-lbs. without additional weights. With the addition of multiple pumpkin weights (150-200-lbs.) and wafer weights (12.5-lbs.), the Lift Load can be configured to weigh between 75 and more than 1,250-lbs. in 12.5-lbs. increments. This allows the user to inspect and test lifts rated up to 1,250-lbs, as well as allowing the user to commission 1000-lbs. tracks to 125% of safe working load as per CSA standards.

In a normal configuration for routine testing the Lift Load is supplied with a cart, two straps, 6 Pumpkin Weights (150-lbs. each), and 10 Wafer Weights (12.5-lbs. each) and has a total weight of 1,100-lbs.



Figure 1: Lift Load

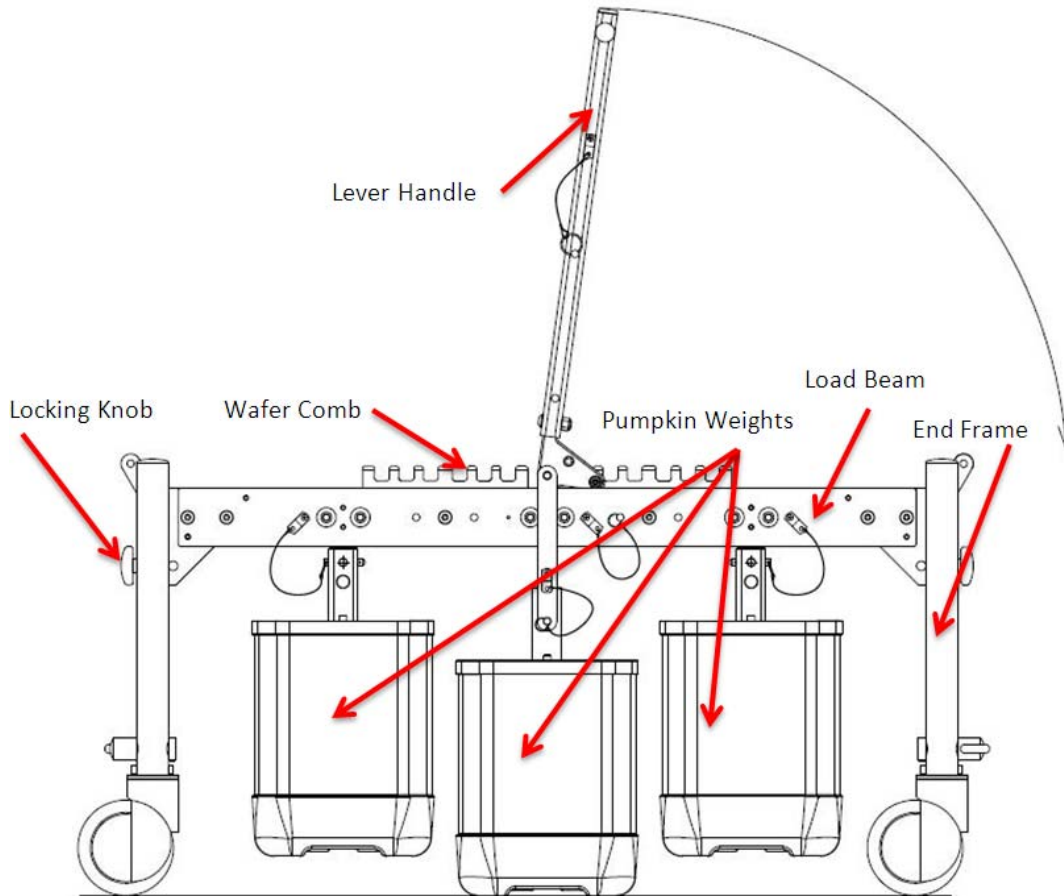

Figure 2: Lift Load Drawing

Table 1: Lift Load Assembly – Parts List

Part Name	Quantity	Physical Description
End Frames	2	Aluminum, protruding bracket, machined notches for load beam locking knobs/bolts, two casters mounted on legs
Load Beams	3	Aluminum, 3 pumpkin post pins, 4 strap loading pins
Lever Handle	1	Aluminum, two lever linkages, triangular fulcrum with bearing rollers
Pumpkin Weights	6	Plastic external housing, 150 lbs., steel post
Wafer Weights	10	Steel, 12.5 lbs. Chamfered edge, machined stacking holes and pins
Wafer Combs	2	Nylon, rest on load beams, slots

		for wafer weights
Castors	4	5" wheels, directional/total lock, polyurethane rolling surface
Straps	2	1" x 2' Edgeguard polyester, Looped 3600-lbs. Choked 2600-lbs.

1.1.1 Frame Assembly

- The end frame components and the load beams are assembled to be the supporting frame that the weights are mounted on. The end frames are identical in construction but have two different sets of castors. One end frame has free-swiveling casters mounted to the legs. The other has castors with a lock/steer feature for ease of maneuvering and safety. The castors are designed to roll over rough and smooth surfaces and are non-marking. Each load beam has identical end mounts. The load beams are anchored to the end frame by a supporting shoulder bolt and a locking knob.
- When assembled the locking knobs (all 6) should be hand-tight and the shoulder bolt resting at the base of the machined grooves on the end frame.
- All three load beams must be assembled to the end frame before transporting or adding weights to the Lift Load. The load beams each have three (3) locations where a Pumpkin Weight can be mounted and have three (3) associated ball detent pins. There are four strap loading pins along the beam. Each strap must only be looped or choker wrapped around one loading pin.

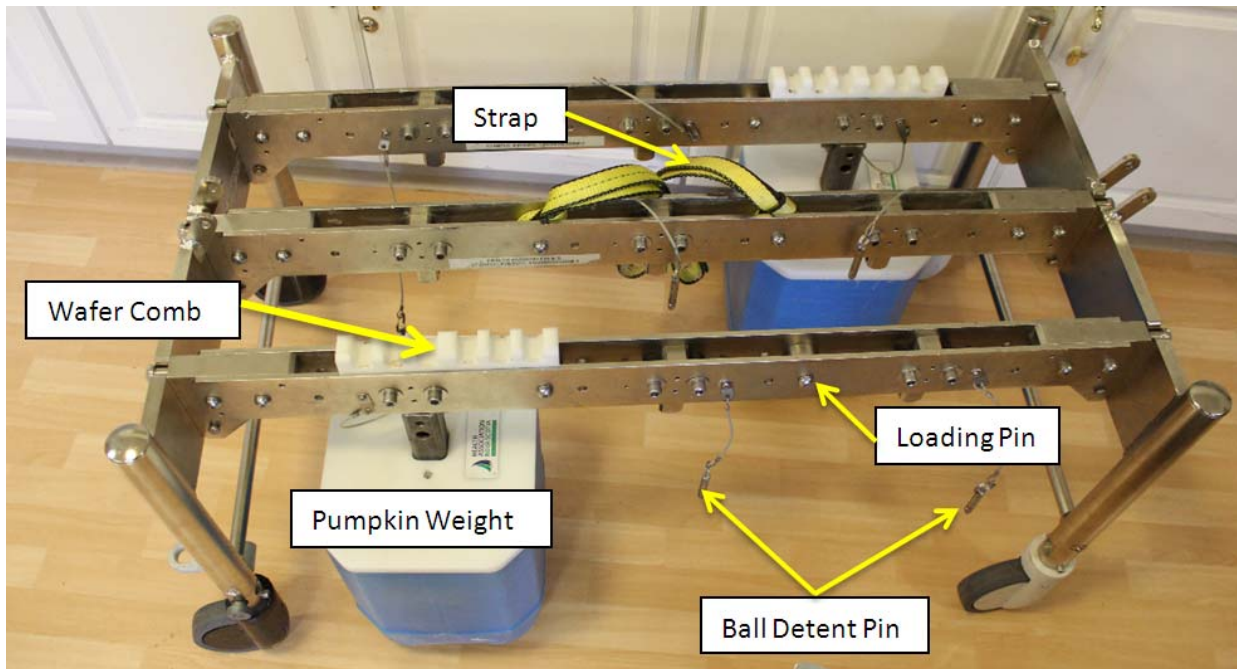

- It is critical that the loading straps are vertical when attached to the patient lift while testing. Failure to maintain vertical strap configurations will place high lateral loads on spreader bars and sit/stand spreader bars and result in damage.
- The lever handle is used as a handle for maneuvering the lift load assembly and as a lever to mount the Pumpkin Weights onto the Lift Load frame. The lever handle is attached to the end frame by a ball detent pin. The pin is pushed through the hole nearest the bearing rollers through the bracket on the end frame. The mounting operation for pumpkin weights is explained in detail with the supplied video.

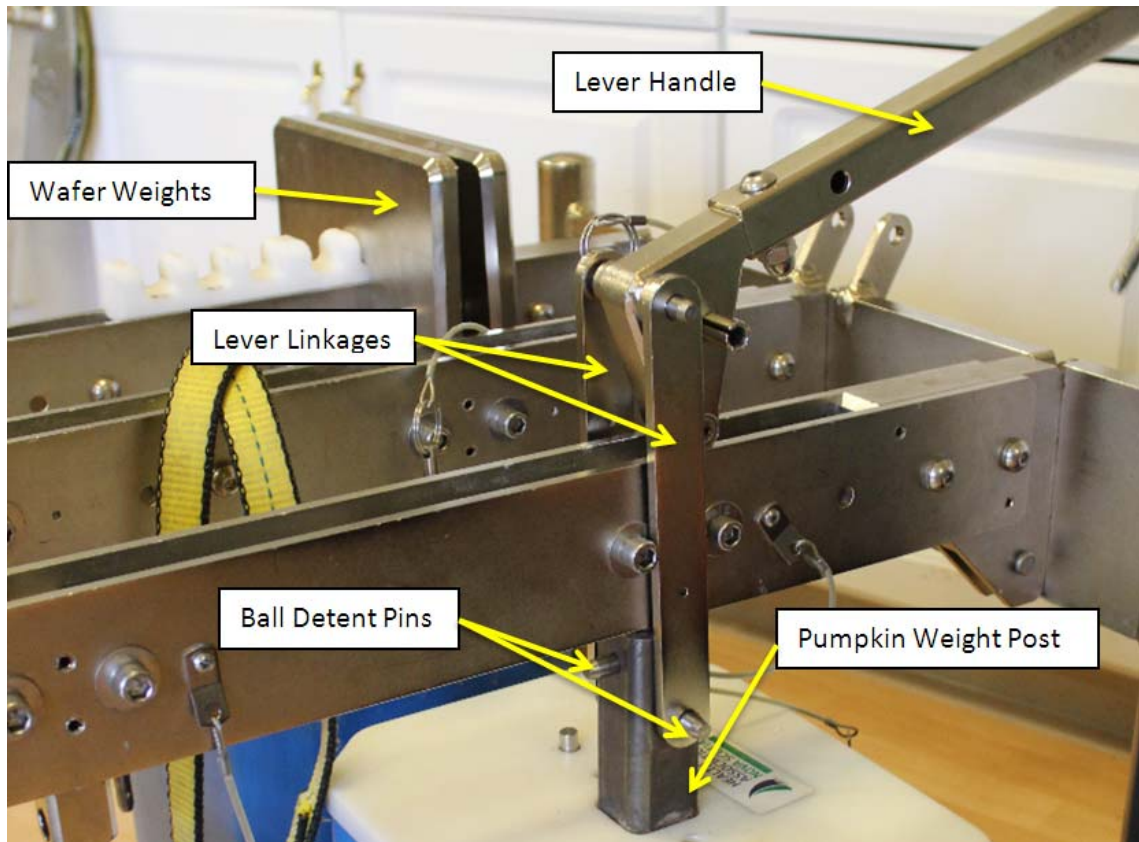

Figure 3: Pumpkin Weight Loading Assembly

1.1.2 Lift Load Weights

- The Pumpkin Weights, named for their size and shape, are 150-lbs. units that can be added incrementally to the Lift Load frame. The pumpkins are made from a plastic shell that is filled with steel and concrete to the specified 150-lbs. (or 200-lbs. in custom applications) and sealed with a machined nylon lid. Two pins on the lid allow the Wafer Weights to be stacked on top of the Pumpkin Weights. For clearance purposes, only two (2) wafer weights should be stacked on top of the pumpkin weights.

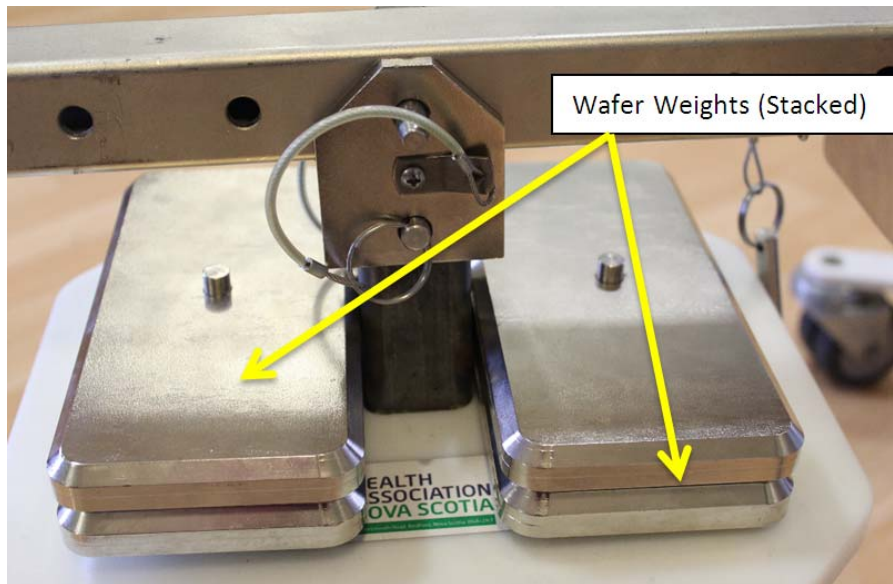

Figure 4: Stacked Wafer Weights

- A center steel post protruding from the top of the Pumpkin Weight is used for mounting onto the Lift Load. The Lift Load can accept up to six (6) pumpkin weights mounted on the load beams. Configurations with the Lift Load allow for balanced loads with 1-6 Pumpkin Weights. Pumpkin Weights are secured to the Lift Load by ball detent pins which pass through the steel post and load beam. These pins are shorter than other ball detent pins used throughout the assembly.
- The Wafer Weights are machined steel plates which rest on the top of the load beams or are stacked on top of the Pumpkin Weights to provide smaller 12.5-lbs. weight increments for lift testing. The wafers are placed within the grooves of the plastic wafer combs to prevent sliding and damage to the Lift Load. The combs and wafers allow the load to be balanced when adding smaller load increments.

1.2 Carry Bar – Testing Accessory

The Carry Bar is a supplementary lift testing device which is used to configure lift tests with constrained loading areas. Such lifts may include tub lifts, sit-stand lifts, and stretcher lifts. If

the entire Lift Load assembly is too large to fit directly underneath the loading surface; the Carry Bar is used instead.

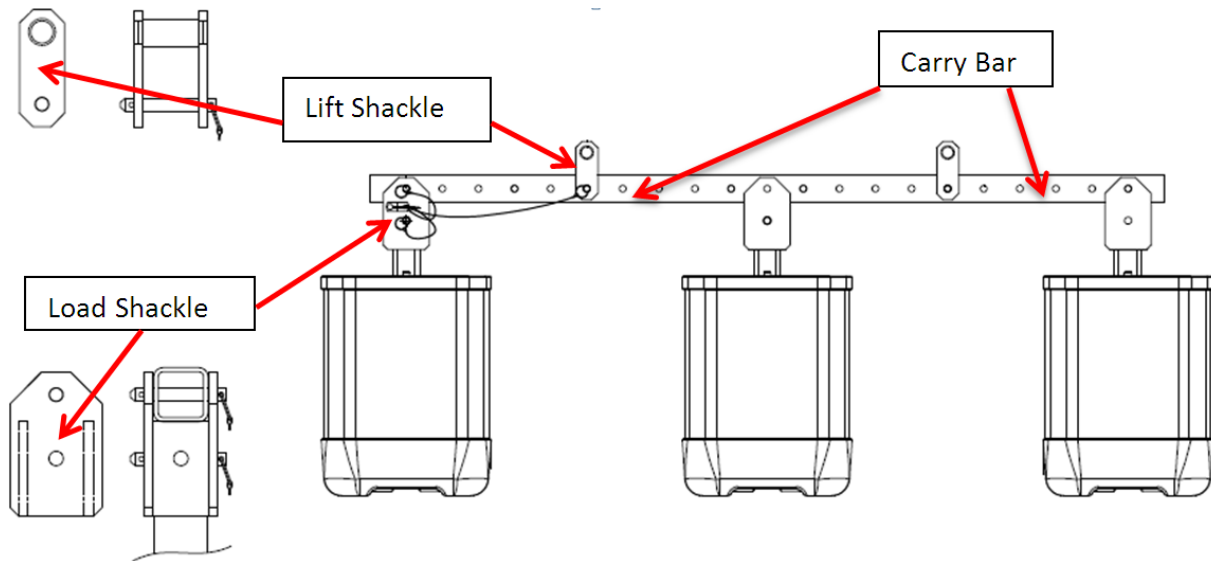

Figure 5: Carry Bar Testing Accessory

Table 2: Carry Bar - Parts List

Part Name	Quantity	Physical Description
Carry Bar	1	Square channel aluminum tubing with equally spaced holes
Load Shackles	3	Aluminum rectangular shackle with holes for carry bar and pumpkin weight mounting
Lift Shackles	2	Aluminum shackle with rounded contour for loading strap, hole for mounting to carry bar

1.2.1 Carry Bar Assembly

- The Carry Bar is assembled by using it as the frame on which the shackles are mounted. The shackles are mounted using the same type of ball detent pins employed on the Lift Load assembly. The shackles are positioned over the desired hole and locked in position

by the ball detent pin. It is crucial that the shackles are mounted symmetrically along the length of the Carry Bar for balanced load testing. The Carry Bar can accept up to three Pumpkin Weights each mounted to the load shackle. For smaller testing weight increments the Carry Bar accepts the wafer plate weights as well (note: the Wafer Weight Comb is not required).

- It is critical that the straps are aligned vertically (near as possible) between the patient/resident lift and the Carry Bar. Failure to do so can result in improper test loading and may cause damage to the lift device.

1.3 Tub Seat Adapter – Testing Accessory

The Tub Seat Adapter is used with lifts equipped with a seat for tub lifts. The lightweight aluminum construction allows the adapter to easily be transferred between lifts in testing.

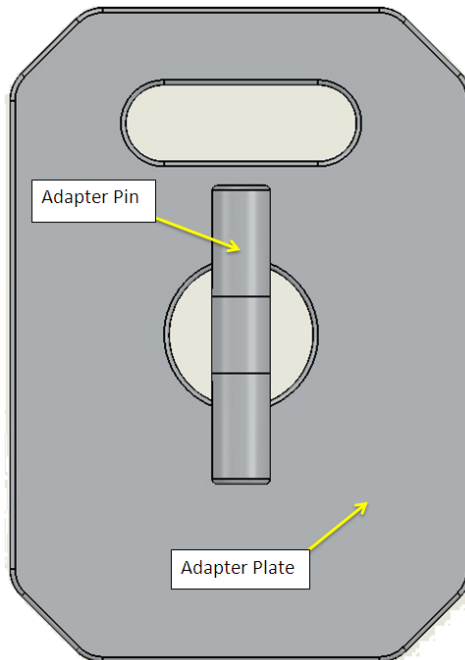

Figure 6: Tub Seat Adapter

Table 3: Tub Seat Adapter – Parts List

Part Name	Quantity	Physical Description
		Aluminum ¼" plate with

Adapter Plate	1	machined holes, recessed positioning magnets
Adapter Pin	1	Large diameter aluminum pin with recessed magnets

1.3.1 Tub Seat Adapter Assembly

The Tub Seat Adapter is placed on top of the sitting surface of tub lifts. The plate has a large circular opening for the loading straps to pass through. The straps loop around the pin to support the weight. Recessed magnets and a machined lip on the pin prevent it from shifting when a load is applied to the Tub Seat Adapter. When using a tub lift with a hard surface seat (plastic or glass reinforced resin), ensure foam or a towel is used between the Tub Seat Adapter Plate and tub seat to distribute the plate load and prevent damage from pressure points.

2 Warnings and Cautions for Use

Failure to adhere to the following may result in damage to equipment and/or facilities; personal injury and/or death:

- ⚠ Lift load, and accessories should be used in accordance with local Occupational Health and Safety regulations. Reference; below the hook devices.
- ⚠ Lift load, and accessories should be used in accordance with the lift the manufacturers specifications. Do not overload lifts or provide stress to the frame of lifts that they were not designed to bear.
- ⚠ Safety shoes/boots must be used during lift testing with the Lift Load, Carry Bar, and accessories. No part of the operator’s body should be under the lift load when testing.
- ⚠ Never lift the load over a patient, resident, or staff. Perform testing in an area where no passing traffic may interfere or be placed at risk.
- ⚠ Routinely inspect the cart for damage, cracks, and loosening of parts and hardware. Welds and fasteners should be inspected annually.
- ⚠ The straps are to be looped over, or choke wrapped around one pin only.

- ⚠ Straps must be vertical when the Lift Load is attached to a patient/resident lift. Damage due to lateral stresses may occur to spreader bars and lift arms if the straps are not vertical.
- ⚠ Lift load is designed to have all three load beams assembled before loading weights or commencing testing. All 6 locking knobs must be hand-tight.
- ⚠ A rolling Lift Load cart has significant momentum when loaded with weight. Be cautious when moving the cart – particularly on ramps.
- ⚠ Straps should be inspected for wear and fraying – replace as necessary
- ⚠ Ensure the lift load or carry beam is balanced for lifting – uneven load distribution may result in load swing and component dislocation.
- ⚠ Any shackles or accessories supplied by the user must be rated appropriately for the weight in use.
- ⚠ Care should be taken in assembly and disassembly of the cart and while adding or removing weights to prevent personal injury. All lifting of weight when moving or assembling cart components must be done as per OHS guidelines in your jurisdiction.
- ⚠ Ensure all pins are fully inserted with the ball detent mechanism locking the pin in position.